

TRAMCO

CENTRIFUGAL DISCHARGE BUCKET ELEVATOR “THE WORKHORSE” ASSEMBLY, OPERATION & MAINTENANCE MANUAL



ORIGINAL INSTRUCTIONS



Read this manual before using product. Failure to follow instructions and safety precautions can result in serious injury, death, or property damage. Keep manual for future reference.

Part Number: 900202 R0

Revised: 20/2/14

This product has been designed and constructed according to general engineering standards^a. Other local regulations may apply and must be followed by the operator. We strongly recommend that all personnel associated with this equipment be trained in the correct operational and safety procedures required for this product. Periodic reviews of this manual with all employees should be standard practice. For your convenience, we include this sign-off sheet so you can record your periodic reviews.

Date	Employee Signature	Employer Signature

a. Standards include organizations such as the American Society of Agricultural and Biological Engineers, American National Standards Institute, Canadian Standards Association, International Organization for Standardization, EN Standards, and/or others.

TABLE OF CONTENTS

1. Introduction	5
2. Safety.....	7
2.1. General Safety Information.....	7
2.2. Assembly Safety.....	8
2.3. Operational & Maintenance Safety.....	9
2.4. Electric Motor Safety	10
2.4.1. Lockout and Tagout Procedures.....	10
2.5. Safety Decals	11
2.5.1. Decal Installation/Replacement	11
2.5.2. Safety Decal Locations	11
3. Assembly	15
3.1. Pre-Assembly	15
3.1.1. Location, Foundation and Elevator Support	15
3.1.2. Shipping Check.....	16
3.2. Lifting and Moving	16
3.3. Centrifugal Bucket Elevator Components.....	17
3.3.1. Head Discharge Section with Drive Shaft.....	18
3.3.2. Boot Section with Take-up Assembly	19
3.3.3. Intermediate Leg Casing Section.....	20
3.3.4. Seals.....	20
3.4. General Assembly Instructions.....	22
3.5. Elevator: Purchased as parts	23
3.5.1. Boot Section	23
3.5.2. Head and Leg Casing	23
3.6. Elevator: Shop-Assembled.....	25
3.7. General Plumbing Instructions	25
3.7.1. Plumb Line.....	26
3.7.2. Transit.....	26
3.8. General Belt & Bucket Instructions.....	27
3.9. Adjusting the Throat Plate Flipper	29
3.10. Check Head Shaft for Level.....	29
3.11. Spouting, Valves, and Fittings	30
3.12. Motor Mount, speed reducer and Drive guard.....	30
4. Operation	31
4.1. Pre-operation/Checklist	31
4.2. Start Up & Break-in.....	31
4.3. General Operation	33
4.4. Shutdown/Storage	33
5. Maintenance.....	35
5.1. Periodic Inspection	36
6. Troubleshooting	37

Terms and Conditions of Sale 41

1. Introduction

The Tramco, Inc. centrifugal discharge bucket elevators are designed and engineered for the bulk handling of free-flowing fine and loose materials with small to medium size lumps. The materials being handled are discharged by a centrifugal action as the buckets pass over the head pulley. The centrifugal discharge bucket elevators are designed to meet your demanding requirements and to be the "work horse" you can count on for years of dependable service.

With multiple bucket materials & configurations, the centrifugal discharge bucket elevator design increases conveying capacity and reduces the product-to-product contamination that you find with other designs. Product features include:

- Rugged, heavy-duty steel construction for durability in the most demanding applications.
- Dust and weather-tight construction to maintain product quality against the elements and prevent dust from escaping.
- Replaceable liners.
- Head and boot are equipped with removable covers to facilitate maintenance.

Before using the centrifugal discharge bucket elevator, give this manual to the people who will be assembling, operating and maintaining this equipment. Reading and understanding the manual will reduce downtime and equipment failure, as well as help to ensure safe and efficient operation. A sign-off form is provided on the inside front cover for your convenience.

The serial number plates are located on the head assembly and on the boot assembly. Please mark the number in the space provided for easy reference.

Model #	
Serial #	
Production Year	

2. Safety

2.1. GENERAL SAFETY INFORMATION



The Safety Alert symbol identifies important safety messages on the product and in the manual. When you see this symbol, be alert to the possibility of personal injury or death. Follow the instructions in the safety messages.

Why is SAFETY important?

- Accidents disable and kill.
- Accidents cost.
- Accidents can be avoided.

SIGNAL WORDS: Note the use of the signal words **DANGER**, **WARNING**, **CAUTION**, and **NOTICE** with the safety messages. The appropriate signal word for each message has been selected using the definitions below as a guideline.

DANGER



Indicates an imminently hazardous situation that, if not avoided, will result in serious injury or death.

WARNING



Indicates a hazardous situation that, if not avoided, could result in serious injury or death.

CAUTION



Indicates a hazardous situation that, if not avoided, may result in minor or moderate injury.

NOTICE

Indicates a potentially hazardous situation that, if not avoided, may result in property damage.

YOU are responsible for the **SAFE** use and maintenance of your equipment. **YOU** must ensure that you and anyone else who is going to work around the equipment understands all procedures and related **SAFETY** information contained in this manual.

Remember, **YOU** are the key to safety. Good safety practices not only protect you, but also the people around you. Make these practices a working part of your safety program.

Important: *Below are general instructions that apply to all safety practices. Any instructions specific to a certain safety practice (e.g., Operational Safety), can be found in the appropriate section. Always read the complete instructional sections and not just these safety summaries before doing anything with the equipment.*



- It is the equipment owner, operator, and maintenance personnel's responsibility to read and understand **ALL** safety instructions, safety decals, and manuals and follow them when assembling, operating, or maintaining the equipment. All accidents can be avoided.
- Equipment owners must give instructions and review the information initially and annually with all personnel before allowing them to operate this product. Untrained users/operators expose themselves and bystanders to possible serious injury or death.
- Use this equipment for its intended purposes only.
- Do not modify the equipment in any way without written permission from the manufacturer. Unauthorized modification may impair the function and/or safety, and could affect the life of the equipment. Any unauthorized modification of the equipment voids the warranty.
- Do not allow any unauthorized person in the work area.

2.2. ASSEMBLY SAFETY

- Have a minimum of 2 people handle the heavy, bulky components.
- Check all equipment for damage immediately upon arrival. Do not attempt to install a damaged item.
- If the equipment must have an open housing as a condition of its use and application, it must be guarded by a railing or fence.
- Use **rugged gratings** where necessary. If the distance between the grating and moving elements is less than 4", the grating opening must not exceed 1/2" x 1" (or 1/2" x 2" for hopper gratings). Covers, guards, and gratings at inlet points must be installed so that personnel cannot be injured in any way.
 - Use solid covers that are designed and installed so that personnel are not exposed to accidental contact with any of the equipment's moving parts.
 - Connect inlet and discharge openings to other equipment in order to completely enclose the equipment.
- As required by the applicable laws, standards, and good practice, the purchaser/ owner is responsible for:
 - guarding all rotating equipment such as drives, gears, shafts, and couplings
 - purchasing and providing safety devices and controls

- Before power is connected to the drive, perform a pre-start-up safety check to ensure the equipment and area is safe and that all guards are in place and secure.
- Electrical equipment must conform to the National Electric Code or National Electrical Safety Code, including requirements for the environment. Also consider:
 - **Overflow devices** (electrical interlocks) to warn personnel and shut off power when discharge from conveyor is interrupted.
 - **Overload protection** for devices (shear pins, torque limiters, etc.) and **no speed protection** (zero-speed switches) to shut off power in the event of an incident that might cause the conveyor to stop operating.
 - **Safety shut-off switch** with power lockout provisions at conveyor drive.
 - **Emergency stop switches** that are readily accessible.
 - **Electrical interlocking** to shut down feeding conveyors whenever a receiving conveyor stops.
 - **Signal devices** to warn personnel of imminent start up of conveyor, especially if started from a remote location.

2.3. OPERATIONAL & MAINTENANCE SAFETY

Operational safety means using common sense and knowing and observing the proper precautions.

- Have another person nearby who can shut down equipment in case of accident. It is good practice to always work with a second person.
- Do not operate equipment with any guard removed.
- Keep body, hair, and clothing away from all moving parts.
- Do not modify equipment in any way. Unauthorized modification may impair function and/or safety, and could affect the life of the equipment.
- Advise all operating personnel of the location and operation of all emergency controls and devices. Maintain clear access to these controls and devices.
- Never walk on equipment covers, gratings, or guards.
- Do not use equipment for any purpose other than that which it was intended.
- Do not poke or prod material into the equipment with a bar or stick inserted through the openings.
- The equipment are not normally manufactured or designed to handle materials that are hazardous to personnel (explosive, flammable, toxic, or otherwise dangerous materials). However, equipment may be designed to handle these materials.
- The equipment are not manufactured to comply with local, state, or federal codes for unfired pressure vessels. For example: If hazardous material is to be moved or if the equipment is to be subjected to internal or external pressure, consult Tramco, Inc. prior to any modifications.
- Be aware of hazardous locations where, without protection, people may be injured by contact with equipment or material. If equipment blocks a walkway, provide a crossover stairway or ramp for passage of personnel. If installed overhead, minimum clearance should be 7" for safety.

- Handling foods subjects equipment to special codes for construction, location, and accessibility. Investigate before ordering standard components!
- Food equipment often require hinged access doors for cleaning, and such doors require special safety controls and procedures by customer to prevent personal injuries. For example: The extensive use of padlocks, with keys in the hands of only management personnel, is one means frequently used.

When performing maintenance, understand and observe the following precautions:

- Do not replace or substitute bolts, nuts, or other hardware that is of lesser quality than the hardware supplied. Consult your dealer for proper replacements.
- Perform frequent inspections of the controls, safety devices, covers, guards, and equipment to ensure proper working order and correct positioning.
- After maintenance is completed, replace and secure all safety guards, safety devices, service doors, and cleanout covers.
- Do not climb ladder if damaged, wet, icy, greasy, or slippery.
- Maintain good balance by having at least two feet and one hand or two hands and one foot on ladder at all times.
- Use required safety harnesses and climbing equipment. Consult local safety authorities.
- Perform maintenance during normal daylight hours or in adequate ambient lighting.

The Conveyor Equipment Manufacturer's Association (CEMA) has produced an audio/ visual presentation entitled "Safe Operation of Screw Conveyors, Drag Conveyors, and Bucket Elevators." Tramco, Inc. encourages acquisition and use of this source of safety information.

2.4. ELECTRIC MOTOR SAFETY

- To prevent serious injury or death, only qualified personnel should service electrical components.
- Keep electrical components in good repair.
- Ground electric motor before using.
- Inspect drive belts before using. Replace if frayed or damaged.

2.4.1. LOCKOUT AND TAGOUT PROCEDURES

To minimize possibility of serious injury or death to workers from hazardous energy release (for example, when restarting the equipment) and prevent worker deaths from all forms of hazardous energy release, follow all lockout and tagout procedures when installing and servicing equipment. Ensure that lockout and tagout procedures are adhered to. For example:

- De-energize, block, and dissipate all sources of hazardous energy.
- Lock out and/or tag out all forms of hazardous energy.
- Ensure that only 1 key exists for each assigned lock, and that you are the only one that holds that key.

- After verifying all energy sources are de-energized, service or installation may be performed.
- Ensure that all personnel are clear before turning on power to equipment.

For more information on occupational safety practices, contact your local health and safety organization.

2.5. SAFETY DECALS

- Keep safety decals clean and legible at all times.
- Replace safety decals that are missing or have become illegible. See decal location figures that follow.
- Replaced parts must display the same decal(s) as the original part.
- Replacement safety decals are available **free of charge** your distributor, dealer, or factory.

2.5.1. DECAL INSTALLATION/REPLACEMENT

1. Decal area must be clean and dry, with a temperature above 50°F (10°C).
2. Decide on the exact position before you remove the backing paper.
3. Align the decal over the specified area and carefully press the small portion with the exposed sticky backing in place.
4. Slowly peel back the remaining paper and carefully smooth the remaining portion of the decal in place.
5. Small air pockets can be pierced with a pin and smoothed out using the sign backing paper.

2.5.2. SAFETY DECAL LOCATIONS AND MESSAGES

Replicas of the safety decals that are attached to the equipment and their messages are shown in the figure(s) that follow. Proper safety procedures require that you familiarize yourself with the various safety decals and the areas or particular functions that the decals apply to, as well as the safety precautions that must be taken to avoid serious injury, death, or damage.

- Place decal 1 on the head and tail sections. Additional placements of decal 1 may be used and their locations are up to the site supervisor.
- Place decal 2 on all head, tail, and intermediate section covers, as well as all inspection and access opening covers.
- Place decal 3 on and behind the belt or chain guard.
- Place decal 4 on the motor conduit boxes.
- Place decal 5 on all explosion vents.
- Place decal 6 & 7 on the head assembly.

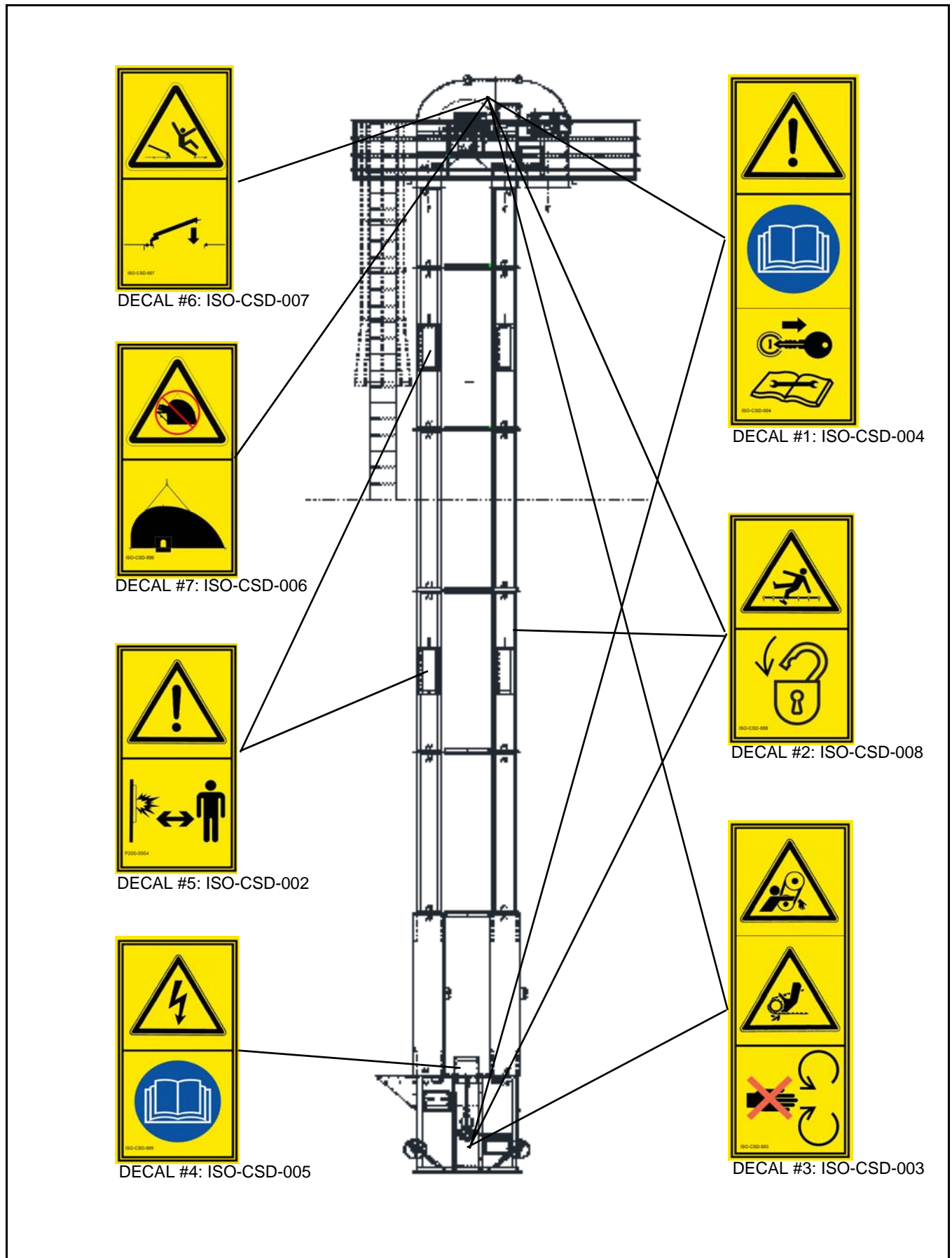

Figure 2.1 safety Decal Locations



DECAL #1: ISO-CSD-004



DECAL #2: ISO-CSD-008



DECAL #3: ISO-CSD-003



DECAL #4: ISO-CSD-005



DECAL #5: ISO-CSD-002



DECAL #6: ISO-CSD-007



DECAL #7: ISO-CSD-006

NOTICE

To prevent damage to the equipment:

- Check bearings weekly for proper operation.
- Lubricate bearings every six months, or after heavy usage, every three months.

See manual for more bearing information and lubrication schedule.

Made in USA ANSI-CSD-N-001-ES

DECAL#1:ANSI-CSD-N-001-ES

NOTICE

For proper operation and to prevent damage to the equipment:

- Check splice protector / wiper cleat for wear and replace if worn.
- Working splice protectors / wiper cleats:
 - prevent product buildup on return pan.
 - ensure proper reloading of product.
 - prevent wearing of the belt splice.

See manual for more information.

Made in USA ANSI-CSD-N-002-ES

DECAL#2:ANSI-CSD-N-002-ES

NOTICE

To prevent damage to the gear reducer, ensure oil is filled to level specified by manufacturer in manual.

Made in USA ANSI-CSD-N-003-ES

DECAL#3:ANSI-CSD-N-003-ES

NOTICE

For proper operation and to prevent product damage:

- Check conveyor belt tension and tracking weekly or more often during seasonal weather changes.
- Check drive belt tension and tracking weekly.
- Conveyor covers must be clamped in place to minimize dust and weather contamination.

Made in USA ANSI-CSD-N-004-ES

DECAL#4:ANSI-CSD-N-004-ES

IMPORTANT

Material must flow evenly down the back slope of the inlet near the speed of the belt for proper loading. This is required for successful loading and operation of the conveyor. See installation manual for further details.

Material Flow →

Made in USA ANSI-CSD-MF-001-ES

DECAL#5:ANSI-CSD-MF-001-ES

IMPORTANT

Material must flow evenly down the back slope of the inlet near the speed of the belt for proper loading. This is required for successful loading and operation of the conveyor. See installation manual for further details.

Material Flow ←

Made in USA ANSI-CSD-MF-002-ES

DECAL#6:ANSI-CSD-MF-002-ES

3. Assembly

WARNING *Before continuing, ensure you have read and understand the relevant information in the safety section. Safety information is provided to help prevent serious injury, death, or property damage.*

3.1. PRE-ASSEMBLY

Important: *Prior to installing, a **licensed structural or civil engineer** must be consulted for the design, construction, and supervision of the complete installation including the foundation, platform and guy wires. A qualified millwright or contractor must be employed to erect the elevator and the accompanying equipment and structures.*

The best bucket elevator improperly installed cannot be expected to offer the performance as designed by Tramco. A properly installed bucket elevator should be the primary concern. Tramco cannot be responsible for the assembly of a bucket elevator. The suggestions and information contained within this manual are offered solely as a convenience as we can assume no liability for installation, either expressed or implied.

3.1.1. LOCATION, FOUNDATION AND ELEVATOR SUPPORT

- The foundation for the bucket elevator must give consideration to live loads, dead loads, wind loads, and soil bearing loads as well as proper moisture run-off on the top of the base.
- Unless the location of the elevator has been pre-determined by a layout drawing, careful consideration should be given to the depth of boot pit, side of boot to be fed, direction of discharge at head, possible overhead obstructions, etc.
- The location of guy wire anchoring points on the ground and on nearby structures must be planned for ahead of time. Bucket elevator will stand vertically, but must be supported with guy wires to protect against wind loads.
- Provide sufficient clearance for guying, anchoring, and bracing. When the bucket elevator is to be fed from a feeder or conveyor, allow for proper clearances for drives, discharges, and valves. Enough clearance should also be provided to allow proper maintenance of the equipment after it has been installed. Thought given to such matters prior to installation can prevent later problems in the flow plan and avoid possible bottlenecks.

IMPORTANT

Other support structures must be provided for accessory equipment such as distributors, cleaners, spouting, etc., since centrifugal discharge bucket elevator will not support such equipment.

3.1.2. SHIPPING CHECK

1. Check if all items in the shipment have been received and inspect if parts are damaged. Inspect casing sections, covers, buckets, chain guards, and drives for dent. Check all bolts including the bearing bolts, elevator bolts, support leg bolts, etc. as they may have loosened during shipping. Tighten when necessary.
2. Check if all loose assemblies listed on the Bill of Material for the bucket elevator have been received.
3. Mark claims for damaged parts on the shipping papers and immediately file a claim. **Do not attempt to install a damaged item.**

Note: *Normal shipping practice will have the head terminal and boot terminal assembled. All other parts will be shipped loose such as leg casing, belt, bucket, ladder, platform, drive components etc.*

For shop-assembled elevators, units are match marked and shipped in the longest sections practical for shipment.

If more than one (1) centrifugal discharge bucket elevator is involved, some items such as flange bolts, etc. may be combined and shipped in one (1) box.

3.2. LIFTING AND MOVING

Take extreme care to prevent damage when moving assembled elevator or components. Spreader bars with slings are the recommended support method for lifting. The unsupported span should be no longer than 10 feet.

Never lift an elevator with only one support point. When choosing supports points for especially heavy items such as drives or gates, consider the weight of an item in relation to load balance and its bending effect.

3.3. CENTRIFUGAL BUCKET ELEVATOR COMPONENTS

Each bucket elevator consists of the following components:

- Head discharge section with drive shaft
- Boot section with take-up assembly and inlet
- Intermediate
- Leg Casing
- Seals
- Elevator buckets and standard belt (belt options available per customer's request)

Graphical representations of the components of the Tramco centrifugal discharge bucket elevator can be found in sections 3.3.1. – 3.3.4.



Figure 3.1

Note: Illustrations in sections 3.3.1. – 3.3.4. are *representative drawings only*. It is the responsibility of the purchaser to consult contract drawings for specific items on each elevator.

3.3.1. HEAD DISCHARGE SECTION WITH DRIVE SHAFT

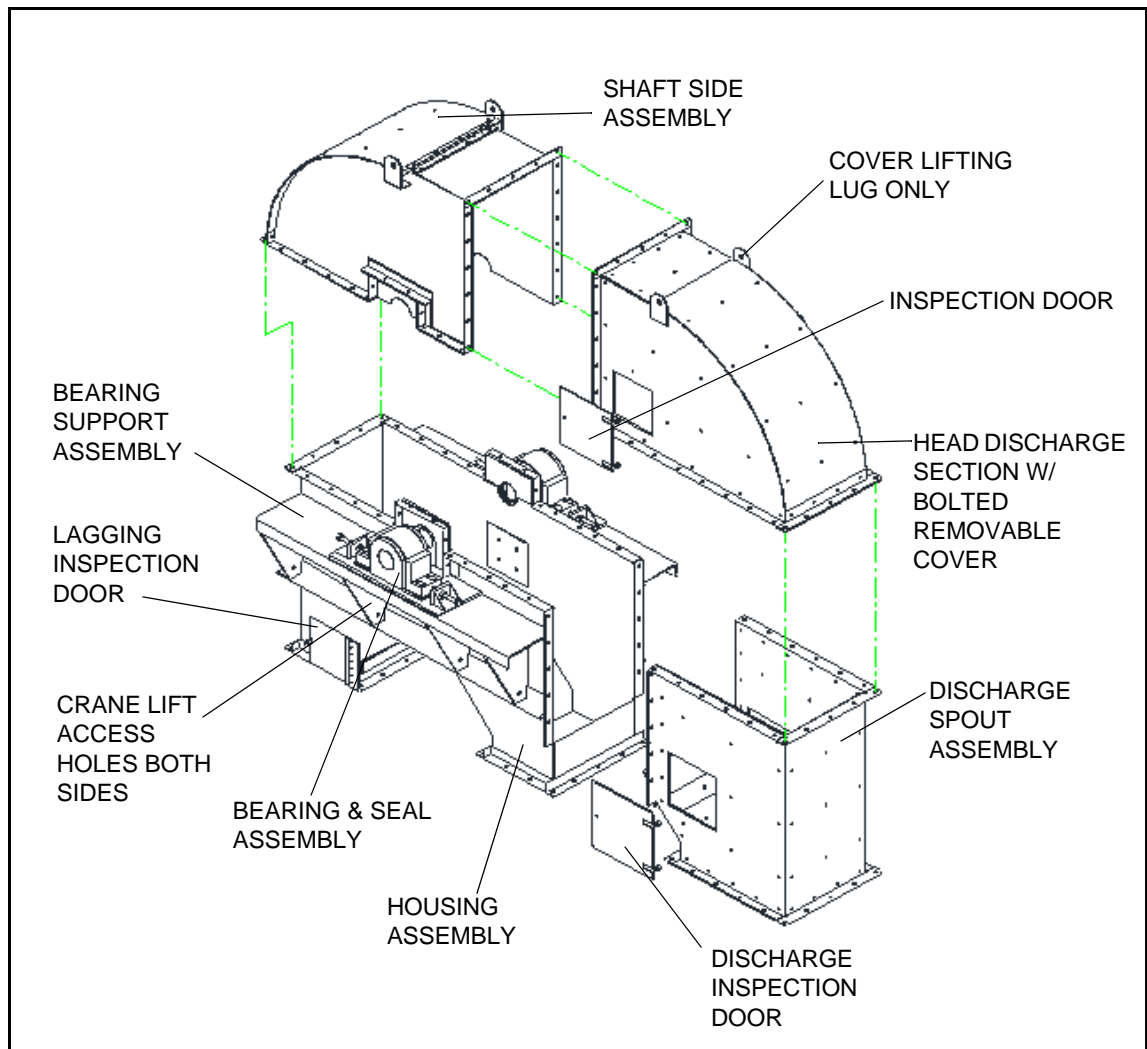

Figure 3.2

Note: *There are bolts on the "Shaft side assembly" that are required to be **REMOVED PRIOR TO INSTALLATION AND OPERATION**. These bolts will have "notice" tags on them with the fore-mentioned instruction.*

3.3.2. BOOT SECTION WITH TAKE-UP ASSEMBLY

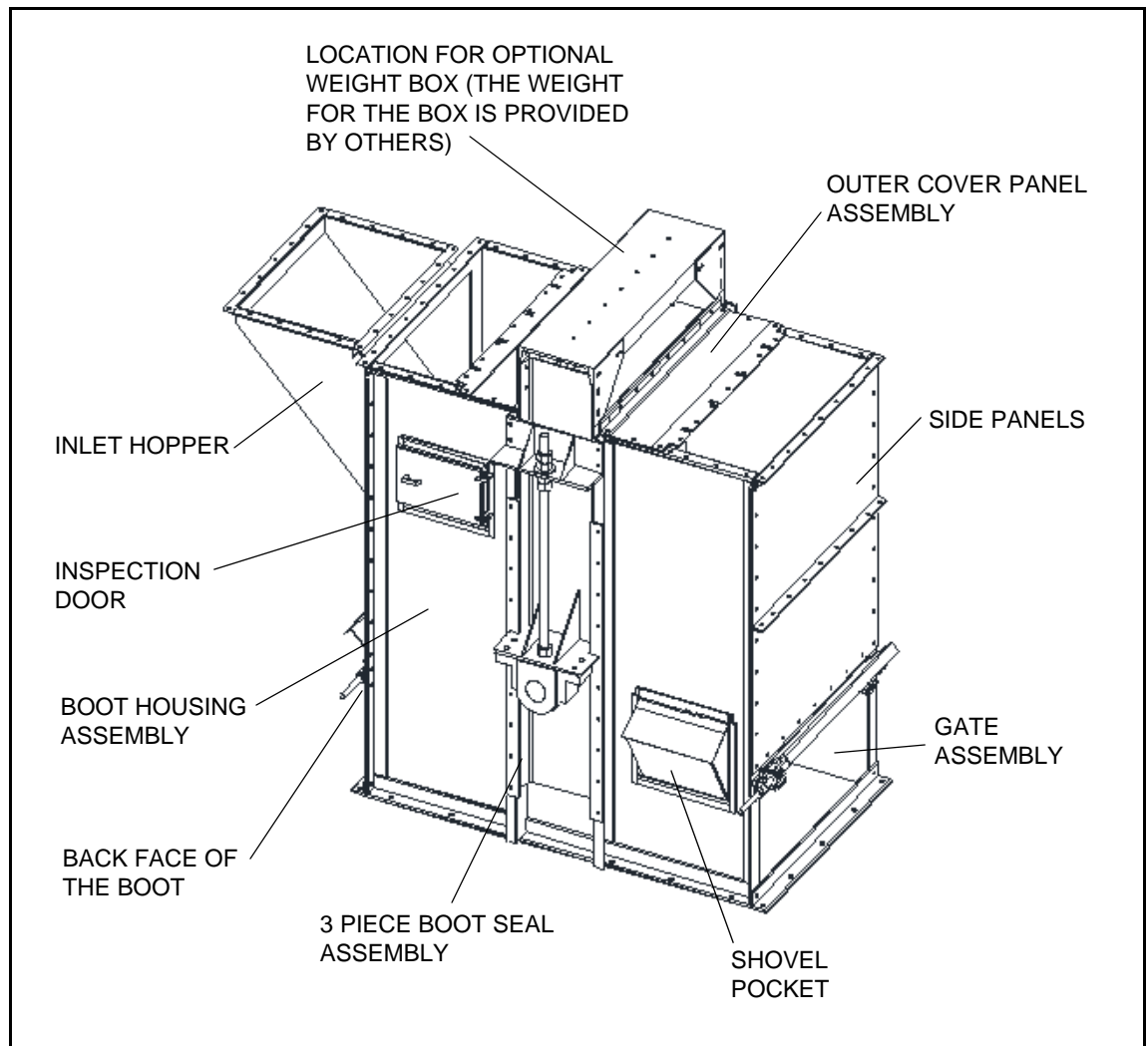

Figure 3.3

Note: *The rack and pinion design of the manually operated clean out slides allows for ease of operation. The clean out slides are located on the "back face of the boot".*

3.3.3. INTERMEDIATE LEG CASING SECTION

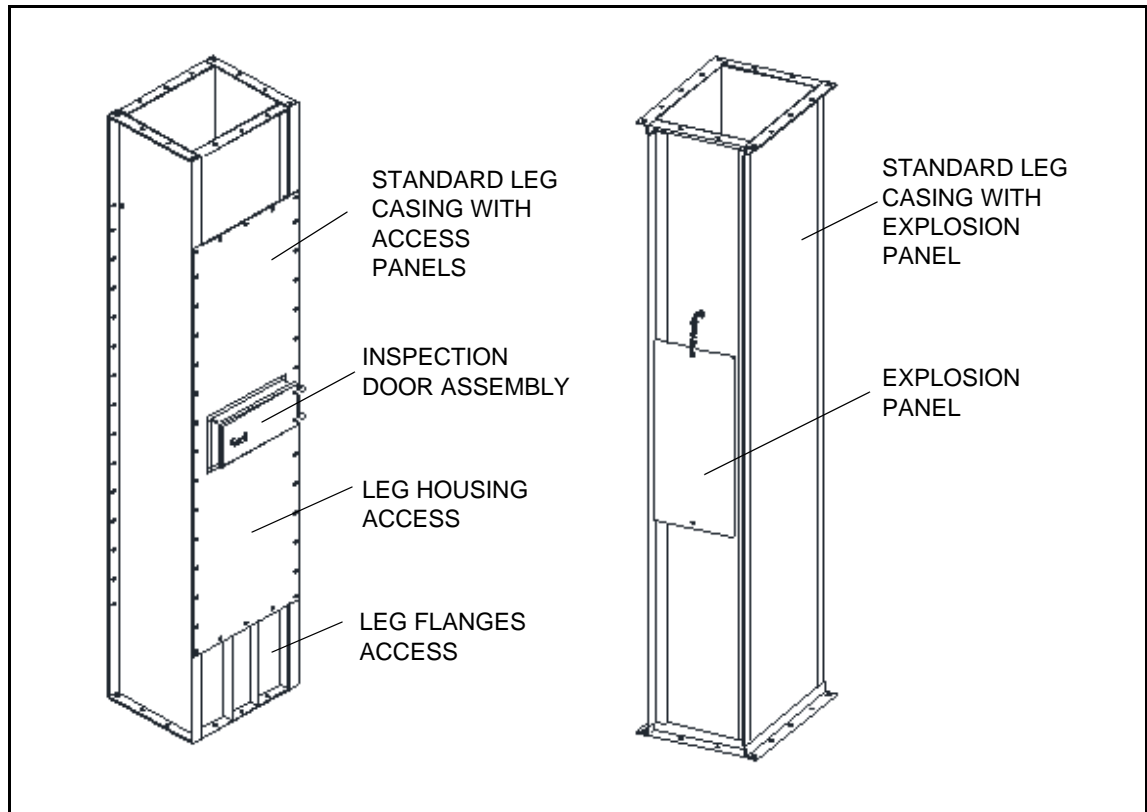

Figure 3.4

3.3.4. SEALS

HEAD SEAL

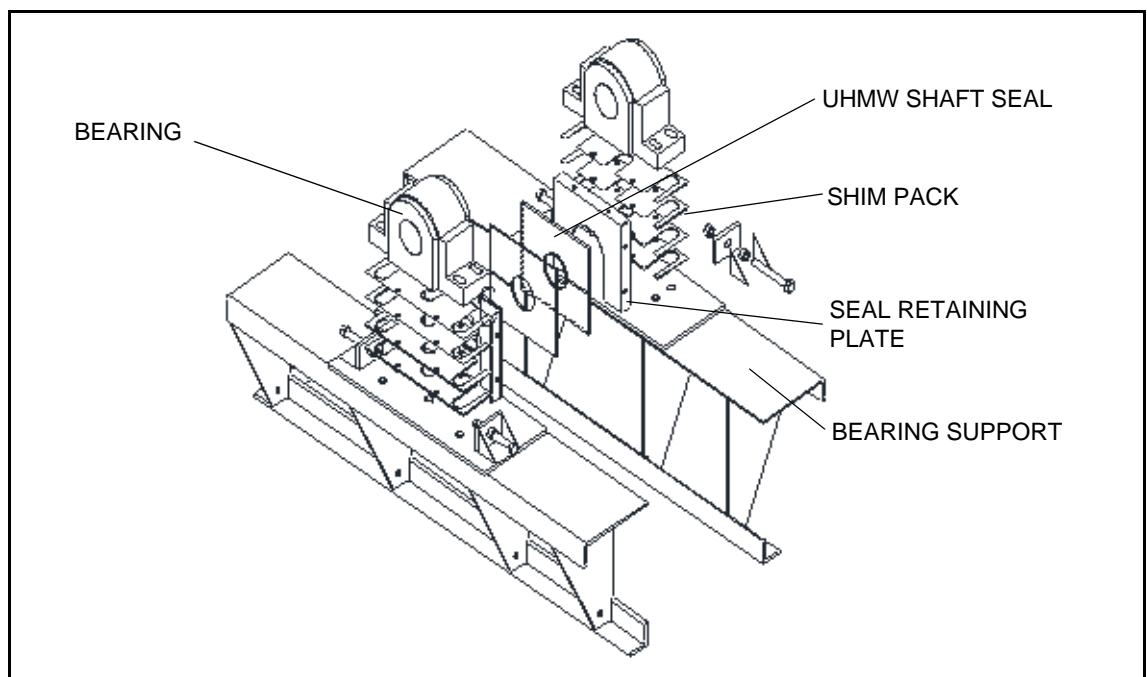

Figure 3.5

BOOT SEAL

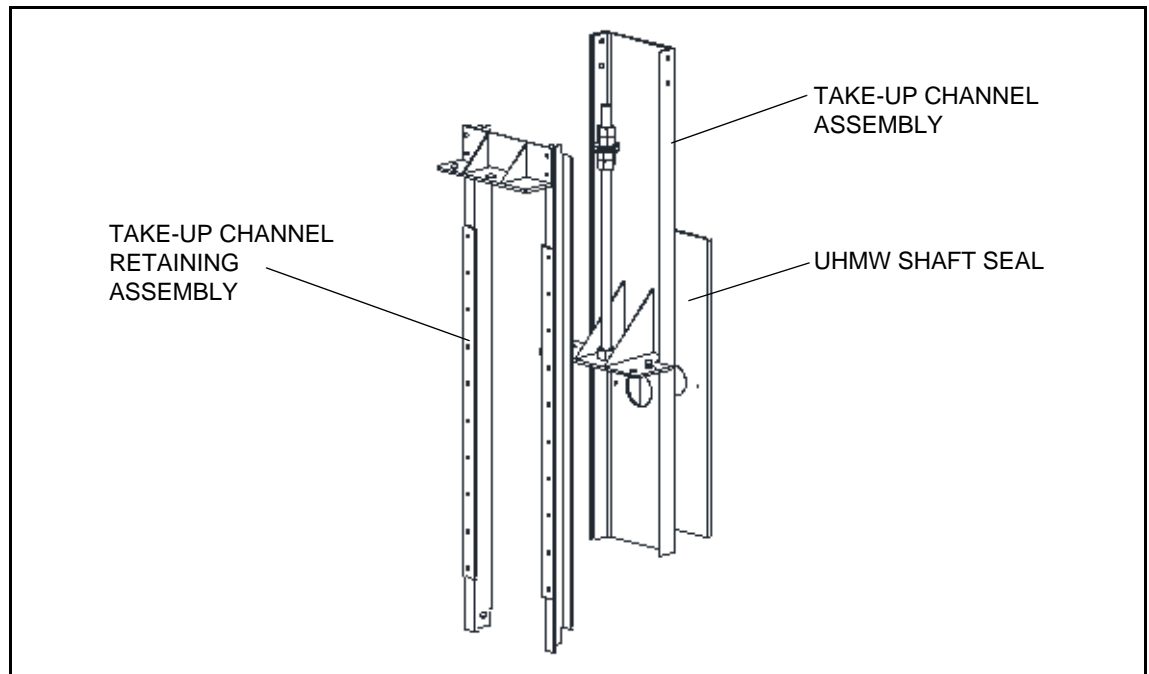

Figure 3.6

3.4. GENERAL ASSEMBLY INSTRUCTIONS

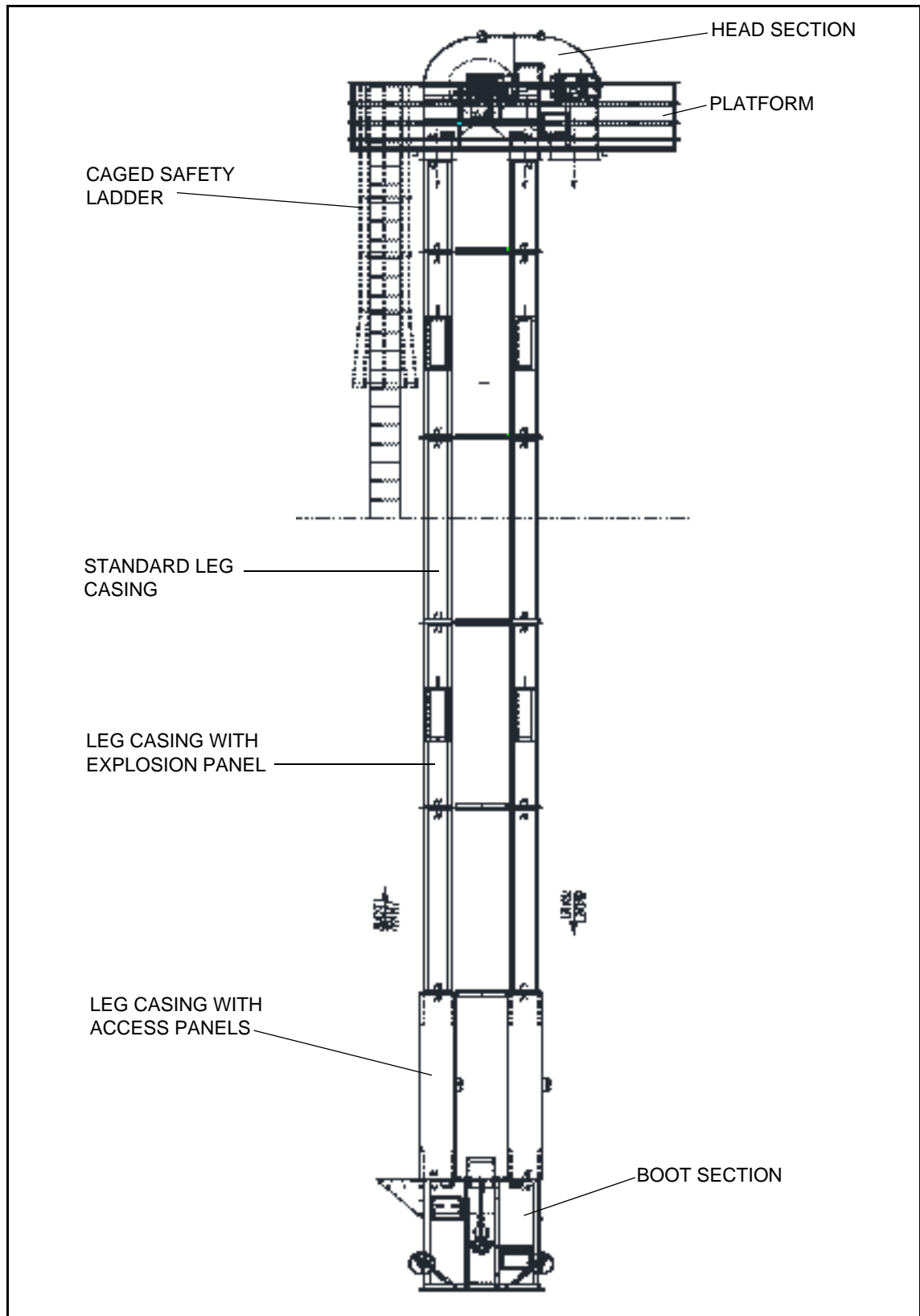

Figure 3.7

Note: *Figure 3.7 is a representative drawing only. It is the responsibility of the purchaser to consult contract drawings for specific items on each elevator.*

Important: *Before starting the assembly, all component pieces (or elevator sections) should be placed in proper sequence as shown in the drawing provided.*

3.5. ELEVATOR: PURCHASED AS PARTS

3.5.1. BOOT SECTION

1. Set the boot on a firm and level foundation. When necessary, use shim to properly level the boot. A boot that is not level makes it very difficult to plumb the elevator.
2. After the boot is positioned and leveled in all directions, anchor it to prevent shifting. Bolts, set in concrete, and plates, overlapping the base flange, are recommended for anchoring.
3. Mount the inlet hopper(s) on the up-side or down-side of the boot, or on both sides, if required (Figure 3.8). It is always best to locate the bottom of the inlet hopper no lower than the center of the boot pulley. Elevator capacity may be reduced if the inlet hopper is located improperly.

Note: *Most free-flowing materials, including whole grains, feed best into the boot on the up-leg side. Feeds for light materials that tend to dust feed best on the down-leg side for better filling of the buckets.*

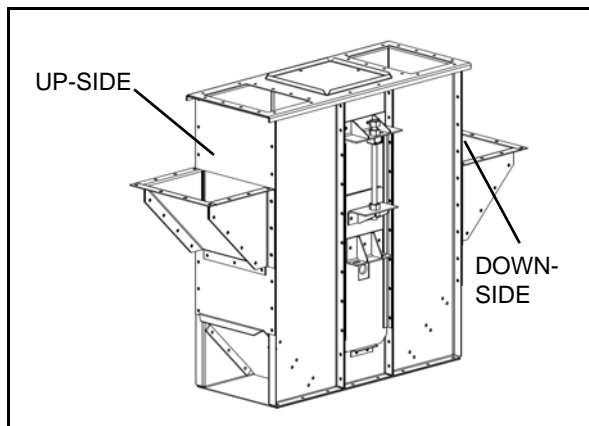

Figure 3.8

3.5.2. HEAD AND LEG CASING

Two methods of assembling the bucket elevator are described below. They differ only in the manner of assembling and erecting the casing.

METHOD 1: ASSEMBLE ON GROUND

1. Erect casing and assemble one piece at a time.
2. Install eyebolts or lifting lugs in the bearing/motor support frame of the head section. Make certain that the bolts or lifting lugs are strong enough to support the head, drive, platforms, ladder, safety cage, and the entire casing. Use cables or chains to attach a crane cable to the eyebolts.

- Using a crane, carefully lift the assembly to an upright, vertical position. Lift the assembly to a height sufficient to allow a single section of casing to be positioned under it and bolted in place. Caulk all flanges to ensure water and dust resistance.

NOTICE

When lifting elevator casing to an upright position, do not allow the casing to drag on the ground.

Flanges and casing sections may be damaged to the extent that assembly and plumbing will be extremely difficult.

DANGER



Ensure the lifting machinery has a capacity that exceeds the weight of the heaviest bucket elevator section/component.

Ensure chains, cables, slings are rated for overhead hoisting and have sufficient lifting capacity for the heaviest bucket elevator component to be lifted.

Important: *When lifting any assembly of the bucket elevator parts i.e. the head and casing, or an assembly of casing, the line of the lifting force should be in line with the narrowest part of a casing section.*

- Assemble ladders, safety cages, platform, and guy brackets, with cables attached, as required. When ladders, safety cages and platforms are furnished by Tramco, detailed instructions are provided with the general arrangement drawing.
- Continue lifting and adding casings until all sections are properly installed. Then, lift and position the complete head and casing assembly onto the boot. Align mounting holes and securely bolt together.

Note: *Refer to the drawing provided to ensure proper location of the inspection section and leg casing with explosion panel.*

- Plumb the bucket elevator assembly in accordance with the instructions in the Section 3.7.
- Ensure all hardware are secure and tight.

METHOD 2: ASSEMBLE SECTIONS VERTICALLY

- Assemble the head, platforms, etc. the same with Method 1.
- Assemble all casing on the ground in assembled sections of 30' or 40'. Caulk all flanges to ensure water and dust resistance.
- Attach ladder and safety cage sections, platforms, and brackets, as instructed by Tramco's general arrangement drawing.

4. Attach a crane to the top end of the first section assembly and lift it into position onto the boot.

DANGER	
	<p>Ensure the lifting machinery has a capacity that exceeds the weight of the heaviest bucket elevator section/component.</p> <p>Ensure chains, cables, slings are rated for overhead hoisting and have sufficient lifting capacity for the heaviest bucket elevator component to be lifted.</p>

5. Install casing to boot flange bolts and tighten.
6. Attach braces and secure.
7. Lift and install remaining assembled sections of casing.

Note: *Refer to the drawing provided to ensure proper location of the inspection section and leg casing with explosion panel.*

8. Install eyebolts or lifting lugs on the bearing/motor support frame of the head section and lift the head assembly into position on top of the casing and secure the flange bolts.
9. Plumb the bucket elevator assembly in accordance with the instructions in the Section 3.7.
10. Ensure all hardware are secure and tight.

WARNING	
	<p>If a cleaner or any other piece of heavy equipment is added, it must be supported from the ground.</p> <p>Additional unsupported weight could damage casing and impair the operation of the Centrifugal Discharge Bucket Elevator.</p>

3.6. ELEVATOR: SHOP-ASSEMBLED

Field assembly can be accomplished by connecting marked joints in accordance with the packing list and/or drawing if applicable. Follow section 3.5.1 to install the boot. Ensure the mounting surfaces for supporting the conveyor is level and true so there is no distortion in the conveyor. Shims or grout should be used when required. Frequently check for straightness during assembly. When joining two flanges, ensure the surfaces have caulk.

3.7. GENERAL PLUMBING INSTRUCTIONS

Leave the crane attached and plumb the Bucket Elevator by either of the two methods described below.

Note: *Be sure turnbuckles are installed in all cables and located so that they may be easily reached for tightening.*

3.7.1. PLUMB LINE

Refer to Figure 3.9.

1. Remove the head cap and drop a plumb line inside the up-leg casing to the boot. Do not allow the line weight to touch the bottom of the boot.
2. Suspend the plumb line on a piece of wood or metal, which will not roll, placed across the top of the head housing.
3. Measurement from the plumb line to side and end of casing housing at the inspection door must be the same measurement taken at the top of the leg. Make all adjustments and then anchor connections before removing the plumb line so that a final check may be made.

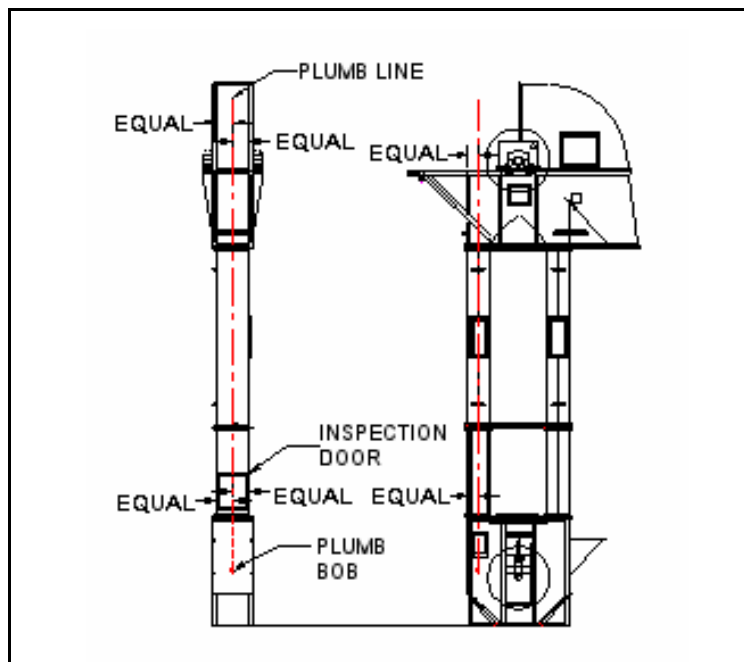

Figure 3.9

3.7.2. TRANSIT

1. If a transit is used, plumb from side-to-side and from front-to-rear.
2. Take as many sightings as necessary (90° apart) to plumb the bucket elevator.

3.8. GENERAL BELT & BUCKET INSTRUCTIONS

The belt can be installed with or without the buckets attached depending on the size of the bucket elevator and the equipment available. Regardless of the method used, the belt is threaded in the same manner.

1. Using the take-up adjustment screws, raise the boot pulley to its highest take-up position (Figure 3.10).
2. Remove the head cover cap and drop a strong rope or cable down the up-leg casing until the end can be removed through the boot hopper opening or the service door in the casing.
3. Attach a rope or cable to the belt. Fabricate two pieces of steel angle to connect the rope to the belt as described in the following steps:

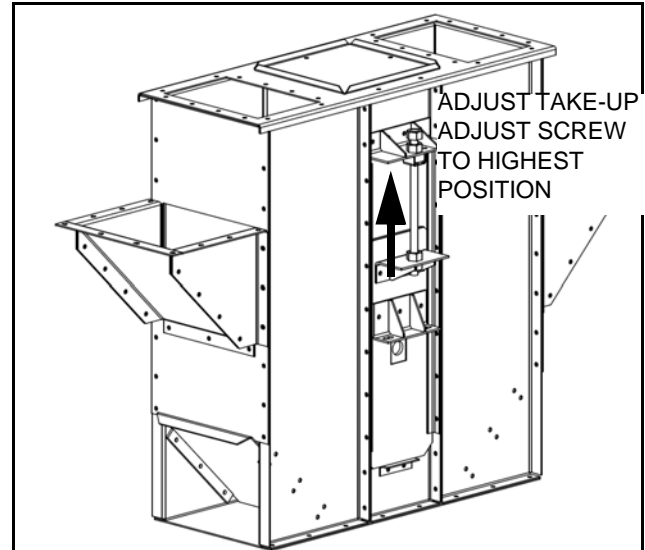

Figure 3.10

- Cut the steel angle the same length as the belt width.
 - Drill holes in one side of steel angle to match the bucket attaching holes in the belt.
 - Drill a single hole in the center of the other side of the steel angle for mounting an eyebolt.
4. Install the eyebolt, attach one steel angle to the end of the belt, and attach the rope or cable.
 5. Use a rope or cable to pull the belt to the head pulley.
 6. Secure the end of the belt in this position and drop the end of the rope or cable down the down-leg casing. Use the hopper opening or cleanout door to thread the rope or cable around the boot pulley and bring it out the hopper or service door opening.
 7. Use the rope or cable to thread the belt over the head pulley and down the down-leg casing and around the boot pulley.

Note: *There are many different ways to splice the ends of the belt. The instructions in steps 8.-12. are for the lap method. The best practice is to use the splice method as recommended by the belt manufacturer. **Tramco, Inc. recommends using a Dura Mechanical splice. Tramco, Inc. supplies the splice template and splicing tools.***

8. Splice the belt by using the lap method. The lead end of the belt (direction of travel), as it is brought up from the boot pulley, must overlap the trailing end of the belt.
9. Using the second steel angle, attach it angle to the belt and use a come-a-long to pull the 2 ends of the belt until the slack is taken up and the bucket attaching holes in the belt are aligned. Bucket attaching holes, which are already punched, are used for bolting the belt end together. Longer bucket

bolts are used for splicing. These bolts also secure buckets on the spliced portion of the belt. The length of the overlap at the splice must cover 5 buckets (Figure 3.11). If possible, allow the belt to hang and stretch for 24 hours.

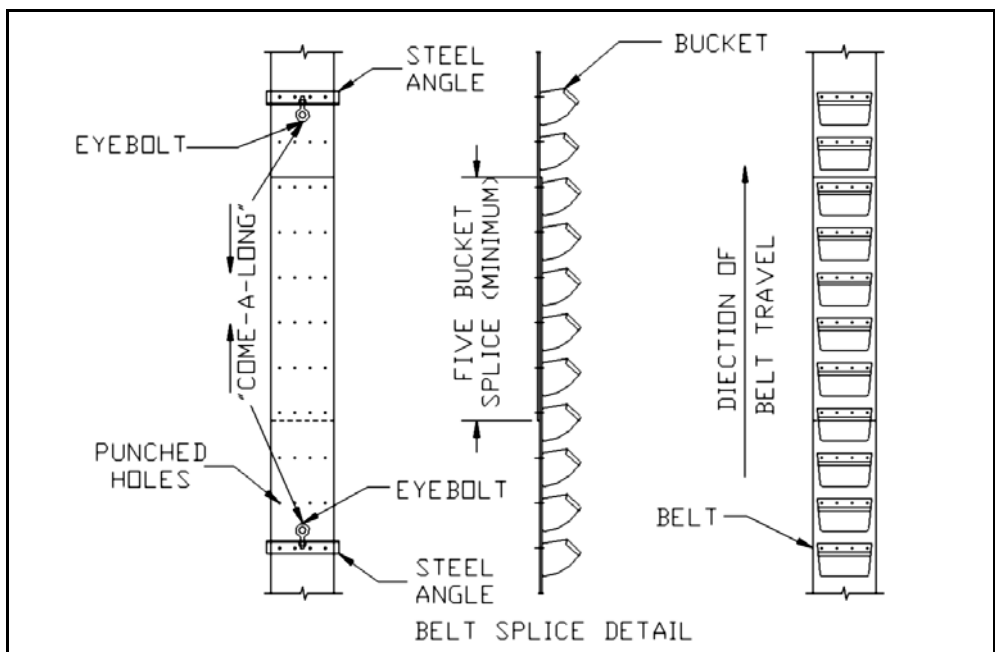

Figure 3.11

10. Pull the leading edge of the belt over the trailing end until slack at the boot pulley is removed and bolt holes are aligned.
11. Refer to manufacturers splice kit instructions to ensure belt is cut square.
12. Insert the bucket bolts from the **back** side of the belt. Mount the buckets on the front side and secure with nuts. Tighten the nuts sufficiently to set the head of the bolt in the belt. Tighten bolts with a speed wrench, or, if an impact wrench is used, exercise care to prevent tightening to the point of fracturing the bolt.

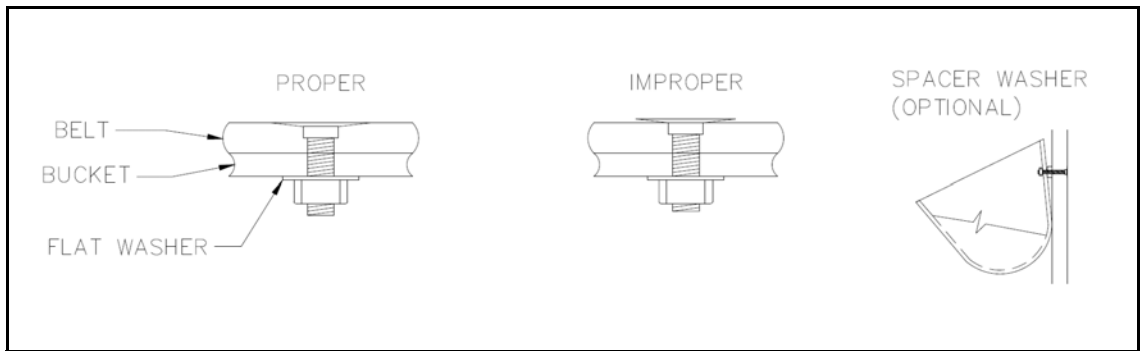

Figure 3.12

13. At this point, the belt has been securely spliced and 5 or more buckets have been installed in the splicing process. The remaining buckets should not be attached at consecutive mounting holes in order to keep each leg of the belt more in balance and to make moving it easier. Attach one bucket at 8–20 row intervals for the first complete belt revolution. On the second revolution, cut the interval spacing in half.

14. Repeat this process on each revolution until all buckets are attached. This procedure will help balance the weight load during bucket installation, particularly on taller Centrifugal Discharge Bucket Elevators.

Note: *After the first week of operation, check and re-tighten all bucket bolts following the bolt manufacturer's torque specifications.*

3.9. ADJUSTING THE THROAT PLATE FLIPPER

1. Before replacing the head cover cap, check the adjustment of the rubber throat plate flipper in the elevator head section. The flipper provides a flexible extension between the throat plate and the lip of the buckets.
2. Adjust the flipper to provide a minimum clearance of 1/2" to 1" between the flipper and the buckets.

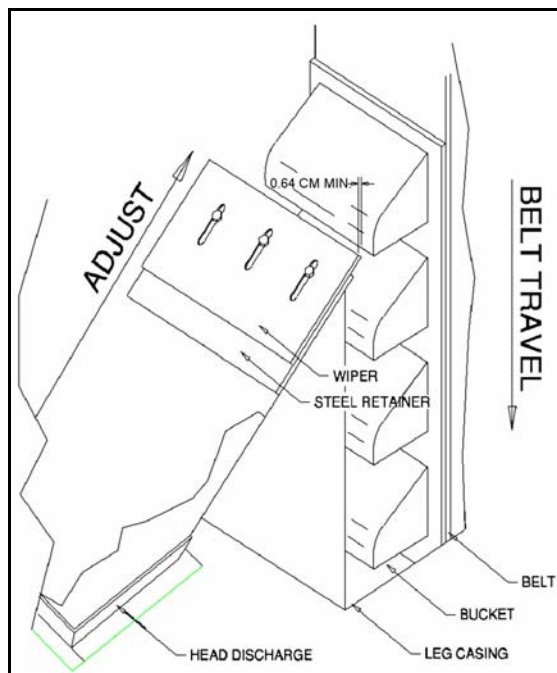

Figure 3.13

3.10. CHECK HEAD SHAFT FOR LEVEL

It is possible that the level condition of shaft could have been altered during shipping and handling. If shaft is not level, install shims under the pillow-block bearing on the low side.

NOTICE

If the head shaft is not level, the belt will not “track” properly and could wear a hole in the side of the head, legging or boot.

3.11. SPOUTING, VALVES, AND FITTINGS

Spouting, valves, etc. are best assembled on the ground and lifted into position with a crane. Apply caulking to all flanges to make a weather-proof joint.

Refer to manufacturers instructions for installation.

3.12. MOTOR MOUNT, SPEED REDUCER AND DRIVE GUARD

Please refer to the general arrangement drawing for illustrations, HP and speed.

4. Operation

WARNING *Before continuing, ensure you have read and understand the relevant information in the safety section. Safety information is provided to help prevent serious injury, death, or property damage.*

Important: *Do not operate Bucket Elevator unless the housing completely encloses the moving elements and power transmission guards are in place.*

4.1. PRE-OPERATION/CHECKLIST

Before operating the bucket elevator, lubricate all bearings and drives per service instructions. Bearings and gear reducers are normally shipped without lubricant. Refer to bearing and gear reducer service instructions for recommended lubricant.

Then do the following:

1. Make certain the Bucket Elevator is plumb.
2. Be sure all guy cables and/or braces are fastened securely and have tension.
3. Check that all hardware (bucket bolts, casing bolts, etc.) is secure.
4. Check all set screws on pulleys, bearings, sprockets, sheaves, gear reducers, etc. Although some set screws may have been installed at the factory, shipment, handling, and installation could have loosened them. Please note that damage caused by loose set screws is not covered by warranty.
5. Check that the head shaft is level.
6. Check for proper rotation of motor and gear reducer and ensure electric motor conduit housing cover is in place. If not in place, lockout the power before replacing the housing covers.
7. Adjust boot pulley take-up so that there is no slack in the belt and so that the boot shaft is level.
8. Lubricate all bearings and drives according to service instructions. **Bearings and gear reducers are normally shipped without lubricant.** Refer to bearing and gear reducer manufacturer's service instructions for recommended lubricant.
9. Check the interior of the Centrifugal Discharge Bucket Elevator to ensure all tools, foreign materials, and other obstructions have been removed.
10. Check to ensure all covers, guards, safety devices or controls, and any interlocks to other equipment are installed and operating properly.

4.2. START UP & BREAK-IN

Operate the empty bucket elevator for 24 hours as a break-in period. Look for bearing heat, unusual noises, or drive misalignment. Should any of these occur, check the following and take corrective steps.

1. When anti-friction bearings are used, check for proper lubrication. Insufficient or excessive lubricant will cause high operating temperatures.

NOTICE

Loose belts and misalignments of leg casings and sprockets can require excessive maintenance and cause poor life expectancy.

2. Check assembly and mounting bolts and set screws; tighten if necessary.
3. Be sure that the belt is properly aligned and running in the center of the head and boot pulleys.
 - If the belt is not tracking in the pulleys, adjust the boot pulley take-up screws so that the belt will track. Remember, a belt will seek the high side of a pulley.
 - You may have difficulty with a belt that does not track even after adjustment of the boot pulley. It may tend to work to one side or the other. This usually means that the bucket elevator has gone out of plumb or the head shaft is not level. Remember that the head shaft and boot shaft must operate parallel to each other.
4. Belting tends to stretch slightly during initial operation. This is not unusual, and special care should be given to belt tension during the first one to two weeks of operation to prevent slippage on the head pulley.
 - Belting manufacturers allow tolerances of 2% to 3% in initial stretch—as much as 2' to 3' in 100' of belting.
 - After frequent belt tightening during the first week, you may need to raise the boot pulley and re-splice the belt to reduce its length. Refer to Section 3.8. Remember, belting will expand and contract under varying conditions of temperature and humidity.
5. After running the conveyor, stop it, lock out all power, and check the inlet hopper and discharge to ensure it is clear and material flow will not be impeded in any way.

WARNING



Amputation Hazard!

To prevent serious injury, lockout power before removing the cover or inspection doors.

6. Restart the conveyor and gradually feed material. Gradually increase feed rate until the design capacity is reached.

Important: *Do not overload bucket elevator. Do not exceed bucket elevator speed, capacity, material density, or rate of flow for which the elevator and drive were designed.*

7. Cut off feed and allow the bucket elevator to empty. Lock out power supply. Check all bolts and all alignments. Re-align as necessary, tighten all bolts, and check chain adjustment.
8. Check motor amperage frequently.

9. Check belt tension periodically. It may be necessary to re-adjust belt tension after running material in the bucket elevator.
10. If “back-legging” occurs in the loaded condition, it could be caused by one or more of the following conditions:
 - The head shaft RPM may be improper if the wrong sheaves for reversing of sheaves on the motor and gear reducer were installed.
 - Restriction at the head discharge or spouting system that is restricting exit of material from the head.
 - Check for a mis-adjustment of the rubber throat flipper in the head. The flipper should have clearance of 1/2” to 1” between it and the lip of the buckets. Refer to Section 3.9.
 - Material is being fed too fast and that the buckets are being overfilled.
11. If the bucket elevator won't be operated for a prolonged period of time, operate until cleared of all material. This is particularly important when the material elevated tends to harden, become more viscous or sticky, or spoils if allowed to stand for a period of time.

4.3. GENERAL OPERATION

1. Run the bucket elevator empty for a few minutes periodically to check for excessive vibration, loose fasteners, security of covers and guards, noise, and bearing and drive temperature.
2. Always operate the bucket elevator with covers, guards, and safety labels in place.
3. Always practice good housekeeping and keep a clear view of the elevator loading, discharges, and all safety devices.

DANGER	
	<p>Rotating parts hazard!</p> <p>To avoid serious injury or death, keep body, hair, and clothing away from rotating pulleys, belts, chains, and sprockets. Keep all guards in place and in good working order. Lockout/Tagout power before removing guard.</p>

4.4. SHUTDOWN/STORAGE

If the bucket elevator will be shutdown for more than one month, perform the following:

1. Remove all foreign material from the bucket elevator and check that the surface coatings are in good order.
2. Lubricate and protect all bearings and drives according to the manufacturer's instructions.
3. Rotate the gear reducer periodically according to the manufacturer's instructions.

4. Protect the elevator from weather, moisture, and extreme temperatures as required. Do not use plastic or other coverings that promote condensation under the covering.
5. Coat all exposed metal surfaces with rust preventative oil. Follow all the manufacturer's instructions that come with the rust preventative oil.
6. Prior to a subsequent start-up, perform the installation and operation instructions in this manual.

5. Maintenance

Proper maintenance habits on the bin unload mean a longer life, better efficiency, and safer operation. Please follow the guidelines below.

WARNING	
	Before performing any internal inspections or maintenance, ensure that a mechanical lockout/ tagout is in place on the motor starter.

Establish routine periodic inspections of the entire bucket elevator to help provide continuous maximum operating performance.

1. Keep the area around the bucket elevator and drive clean and free of obstacles for easy access and to avoid interference with the function of the bucket elevator and drive.
2. The shaft mounted gear reducer is lubricated by an oil reservoir in the housing. The correct amount of oil is important to the proper operation of the reducer. Too much oil may cause leakage or overheating. Too little oil may cause overheating or damage to internal parts. The gear reducer's maintenance instructions provide a list of recommended lubricants and oil change periods.
3. Check oil level.
4. Keep breather openings clear at all times to prevent pressure build-up in the reducer.
5. All bearings used on the bucket elevator are anti-friction, ball, or roller type pillow blocks. Check the bearing's maintenance instructions for the type of grease and the lubrication intervals.
6. The frequency of lubrication depends on several conditions such as hours of operation, temperature, moisture, speed, and contaminants.
7. When lubricating, the bearing manufacturer recommends that you add grease slowly and use a sufficient volume to purge the bearing of old lubricant. It is preferable to rotate the bearings during lubrication where good safety practice permits.
8. Immediately investigate any unusual noise or vibration change.
9. Check the belt frequently to make certain that it is running in the center of the pulleys and properly tensioned to prevent slippage on the head pulley.
10. Check and tighten all bucket bolts after the first week of operation. Check on a regularly basis from here on out.
11. Establish routine periodic inspections of the entire bucket elevator to ensure continuous maximum operating performance.
12. Replacement parts can be identified from a copy of the original packing list, invoice, or drawing.

5.1. PERIODIC INSPECTION

Casing	Check for wear and alignment.
	Tighten all bolts to manufacturer's torque specifications.
Shafts	Check for wear and misalignment.
Buckets	Check for wear or damage.
Nuts & Bolts	Check for wear and tightness.
Seals	Check for leakage, adjustment, and wear.
Bearings	Check for lubrication and noise.
Pulleys	Check for wear and alignment.
Belt	Check for damage and alignment.
Take-up	Check belt tension, (If take-up is fully adjusted, a section of belting will need to be removed).
	Adjust take-up to remove excess slack from the belt. Make sure the adjustment screws have been tightened equally to prevent misalignment.
Gear Reducer(s)	Check for oil level and noise.
V-Belt/Chain Drive	Check belt/chain tension and adjust as required.
Guards	Check for oil level (if applicable). Check nuts and bolts for tightness.
Motors	Check amperage frequently. Verify it is within operating parameters.

6. Troubleshooting

In the following section, we have listed some causes and solutions to some of the problems you may encounter in the field.

If you encounter a problem that is difficult to solve, even after having read through this troubleshooting section, please contact your local dealer or distributor. Before you contact them, please have this operation manual and the serial number from your machine ready.

WARNING	
	<p>Fully disengage and lock out the power source before attempting any modifications or repairs.</p>

PROBLEM	CAUSE	SOLUTION
Back legging. Material falling down the up or down side casing.	Obstruction in head	Inspect head for foreign materials.
		Check for missing buckets. Replace missing buckets.
	Throat flipper is out of adjustment.	Remove head cover cap and adjust flipper
	Obstruction in distributor or spouting.	Inspect distributor and spouting. Correct condition as required.
	Buckets being overfilled.	Remove inspection door and use a strobe light, while elevator is running, to see if buckets are being overfilled. Buckets should be near full, but not overflowing.
	Head shaft running too fast.	Check the drawing to be sure the correct Sheave is installed.
	Spouting size too small for elevator capacity.	Use the correct size spouting. Re-examine the engineering design.
	Spouting is installed too flat for good flow.	
	Spouting has a sharp bend that restricts the flow.	
	Bucket loose.	Tighten all bucket bolts securely.
	Damaged buckets.	Replace as required. Determine cause of damage.
	Elevating light material.	Replace buckets with perforated buckets.
	Belt loose.	Tighten take-up screws or re-splice the belt as required.
Air locked.	Ventilation may be needed at the boot or in the load.	

PROBLEM	CAUSE	SOLUTION
Elevator being overloaded	Feed conveyor running too fast.	Check conveyor speed.
	Pit hopper baffle mis-adjusted.	Adjust to restrict flow of material.
	Head pulley running too slow.	Check pulley speed.
		Checks drawing to be sure the correct Sheaves are properly installed.
Check gear reducer for correct reduction ratio.		
Low capacity	Head shaft speed is too slow.	Check pulley speed.
		Check sheaves, gear reducer, and motor to determine cause of slow speed. Correct as required.
	Feed conveyor is running too slow or is obstructed.	Check conveyor speed. Correct as required. Remove any obstructions.
	Baffle plate in the pit hopper adjustment is set too low.	Raise baffle plate.
	Obstruction in the boot or the feeding boot is in the wrong location.	Clean boot and remove any obstructions. Check recommendations for locations of inlet hoppers.
	Missing buckets.	Missing buckets.
	Elevating light material.	Use perforated buckets.
	Air lock.	Install vents in the bins being loaded, the elevator head or boot.
	Spouting is too small or installed too flat for good flow.	Check recommendations for sizing and slope.
	Belt is loose.	Check for slippage. Check head pulley for lagging and replace if worn.
	Buckets are damaged or caked with material.	Visually inspect, clean, or replace damaged buckets.
Bearing failure	Material getting into the bearing.	Add or upgrade seal to keep material out of bearing.
Belt not tracking in the center of the pulleys. Belt rubbing on the sides of the head, boot, and/or casing	Boot pulley is improperly adjusted.	Adjust take-up screws on the boot to level the pulley and align belt in center of pulley.
	Elevator casing out of plumb, twisted, or bent.	Correct out of plumb condition.
		Replace or repair bent casing.
	Head pulley not level.	Place shims under pillow block bearings to level pulley.
	Head pulley is lagging down.	Replace with new lagging kit.
	Pulley has no crown.	Replace pulley.
	Failed bearings.	Replace defective bearing on head or boot shaft.
Possible materials build up on pulley.	Clean pulleys or use slotted pulley at the boot.	

PROBLEM	CAUSE	SOLUTION	
Bucket bolts pull through belt or belt tears at bolt holes.	Bucket bolts not tight.	Frequently inspect and tighten the bucket bolts.	
	Inadequate belt construction for bolt holding.	Replace the belt with the proper design.	
	Obstruction in casing or insufficient clearance.		Remove the obstruction.
			Check the belt for proper tracking and align pulleys if required.
			Check casing for proper bucket clearance.
	Jammed boot.	Clean out boot.	
	Pulleys are too small or incorrect splice strains the bolts as the belts flexes.	Install larger head pulley if possible. Check possibility of using thinner belt.	
	Lump size or weight in buckets increased from original design.		Change feed design in boot to handle larger lumps.
		Change to heavier belt.	
Excessive belt slippage or burning.	Head pulley lagging, worn, or loose.	Replace with factory recommended lagging.	
	Belt has stretched.	Adjust belt tension with boot pulley. Adjust take up screws, or re-splice the belt.	
Belt covers wearing excessively on bucket side.	Material down lagging and getting between the bucket and belt.	Change speed to affect better discharge.	
	Fine abrasive material between the bucket and belt.	Install rubber washers or bucket pads between the bucket and belt.	
	The cover gauge is too light or improper belt quality.	Upgrade the belt.	
Belt carcass breaks.	Lumps dropping between belt and boot pulley.	Use slotted boot pulley.	
	The operating tension is higher than maximum allowable working tension of belt.	Replace belt with correct design.	
Caking on buckets	Wet or powder type material.	Material is too wet.	
Damaged buckets	Belt loose.	Tighten take-up screws or re-splice belt as required.	
	Casing bowed and catching.	Re-plumb as required.	
	Obstruction in the elevator.	Repair or remove.	
	Buckets too large for casing.	Replace with proper size.	
	Belt not running smooth.	May require special splice.	
Excessive wear on pulley side of cover.	Abrasive material between belt and boot pulley.	Clean out boot.	
	Belt slips at head pulley.	Replace worn lagging.	
		Adjust take-up screws to increase belt tension.	
The cover gauge is too light or improper belt quality.	Upgrade belt		

PROBLEM	CAUSE	SOLUTION
Build up on boot pulley.	Powder or sticky material	Slotted boot pulley required.

TERMS AND CONDITIONS OF SALE

LIMITED WARRANTY AND TERMS OF SALE WARRANTY:

TRAMCO, INC. products are sold with a warranty against defects in material and workmanship for a period of one year from the date of their delivery to the purchaser or their delivery to the carrier in the case of F.O.B. Shipments. TRAMCO, INC.'s warranty shall be limited at TRAMCO, INC.'s option to repair or replacement of any defective parts or components. Such repair or replacement shall be the purchaser's exclusive remedy hereunder and correction of defects shall constitute complete fulfillment of all obligations and liabilities of TRAMCO, INC. with respect to the product sold hereunder, whether based in contract, tort, or otherwise. The determination of a defective condition shall be made by TRAMCO, INC. in its sole discretion.

LIMITATION OF LIABILITY:

TRAMCO, INC. shall not be liable, in contract, tort, or otherwise, for any special indirect, incidental, or consequential damages, such as, but not limited to, loss of profits, loss of production, or for injury or damage, caused by reason of the installation, modification, use, repair, maintenance, or mechanical failure of any TRAMCO, INC. product. TRAMCO, INC.'s warranties hereunder extend only to the direct customer of TRAMCO, INC. TRAMCO, INC. makes no warranties of any kind with respect to improperly installed product or equipment unless the direct customer of TRAMCO, INC. (or first user, as the case may be) first fully discloses in writing to TRAMCO, INC. the method and details of the proposed installation and the intended use of the product or equipment and TRAMCO, INC. approves in writing of such method and details. TRAMCO, INC. makes no warranties when damage results from the failure to follow instructions in the manual or in safety labels attached to the TRAMCO, INC. system. The purchaser or user of any TRAMCO, INC. equipment shall be responsible for all ordinary maintenance, adjustments, and cleaning of the product. In the event that the TRAMCO, INC. product is not properly maintained, all warranties by TRAMCO, INC. are null and void. Certain of the component parts of the TRAMCO, INC. product are purchased from other vendors. TRAMCO, INC. warrants these component parts only to the extent of the vendor's warranties. TRAMCO, INC. shall repair or replace such component parts in accordance with the vendor's warranty policy only if TRAMCO, INC., in its sole discretion, determines such component parts to be defective.

LOSS, DAMAGE OR DELAY:

TRAMCO, INC. shall not be liable for any loss, damage, detention or delay resulting from any cause beyond its reasonable control, including, but not limited to, fire, strike or other concerted action of workmen, act or omission of any governmental authority or of the purchaser, insurrection, riot, embargo, transportation, shortage, delay or wreck, or inability to obtain labor or material from usual and customary sources.

WARRANTY DISCLAIMER:

TRAMCO, INC. MAKES NO WARRANTIES OTHER THAN THOSE STATED HEREIN, AND THESE WARRANTIES ARE EXPRESSLY IN LIEU OF ALL OTHER WARRANTIES, WHETHER EXPRESS OR IMPLIED, INCLUDING BY WAY OF EXAMPLE AND NOT BY WAY OF LIMITATION, ANY WARRANTIES OF MERCHANTABILITY OR FITNESS FOR A PARTICULAR PURPOSE, AND ALSO IN LIEU OF ANY OTHER OBLIGATIONS OR LIABILITIES ON THE PART OF TRAMCO, INC..

MODIFICATIONS:

The prices and terms of this offer are not subject to verbal changes or other agreements unless approved in writing by an authorized representative of TRAMCO, INC. management. No representation or warranty, express or implied, made by any sales representative or any agent or employee of TRAMCO, INC. which is not specifically set forth herein shall be binding on TRAMCO, INC. unless approved in writing by an authorized representative.

TAXES:

Unless otherwise noted, the price does not include any state or local property, sales, use, or privilege tax or license. If any such charge should be enforced by virtue of the transaction described herein, the purchaser agrees to pay the same or reimburse TRAMCO, INC., as the case may be.

LOSS OR DAMAGE IN TRANSIT:

Any claim for loss or damage to products in transit must be entered and prosecuted by the purchaser.

RISK OF LOSS:

Delivery shall occur and the risk of loss shall pass to the purchaser upon delivery of the material to the carrier at the point of shipment. Any claim of loss or damage in transit shall be against the carrier only.

GENERAL PROVISION:

The failure of TRAMCO, INC. to enforce any right will not be construed as a waiver of TRAMCO, INC.'s rights to performance in the future. The purchaser may not assign any rights or delegate any performance owed under this agreement without the express written consent of TRAMCO, INC. management.

CLAIM/NOTICE OF DEFECTS:

In the event the purchaser claims that a TRAMCO, INC. product is damaged upon receipt, TRAMCO, INC. shall be given an equal opportunity for inspection, or, upon request, shall be furnished a sample of such product. The purchaser shall set aside, protect and hold such products without further processing until TRAMCO, INC. has an opportunity to inspect and advise the purchaser as to the disposition, if any, to be made of such products. In no event shall any TRAMCO, INC. product be returned, re-worked, or scrapped by the purchaser without the express written authorization of TRAMCO, INC.

PATENT RIGHTS:

The purchaser agrees not to violate or infringe the patent rights relating to any TRAMCO, INC. product or any other patent rights under the control of TRAMCO, INC. or under which TRAMCO, INC. has the right to manufacture or sell. The purchaser also agrees not to contest TRAMCO, INC.'s title to any and all such patent rights, nor the validity or scope thereof. The purchaser assumes liability for patent or copyright infringement when goods or products are made to the purchaser's specifications.

NON-INCORPORATION:

Any terms inconsistent with those stated herein which may appear in the purchaser's formal order or in any proposal for additional or different terms, or any attempts by the purchaser to vary in any degree any of the terms of this offer, are hereby objected to and rejected, but such proposal shall not operate as a rejection of this offer unless such variances in the terms and the description, quantity, price or delivery schedule of the goods or products are deemed a material alteration thereof, in which event this offer shall be deemed accepted by the purchaser without said additional or different terms.

GOVERNING LAW:

All disputes arising out of this offer and purchase order shall be governed by the laws of the State of Kansas.

JURISDICTION AND VENUE:

The purchaser consents to the personal jurisdiction of the federal and state courts in the State of Kansas, waives any argument that such a forum is not convenient, and agrees that any litigation relating to this offer and purchase order shall be venue in either the Circuit Court of Sedgwick County, Kansas, or the Federal District Court, District of Kansas.

SEVERABILITY:

If for any reason any one or more of the provisions contained in this offer are held to be invalid, illegal, or unenforceable in any respect, such invalidity, illegality, and unenforceability shall not affect any other provision hereof and this offer shall be construed as if such invalid, illegal, or unenforceable provision had never been contained herein.

ATTORNEYS' FEES:

The purchaser agrees that in the event there is a dispute between the parties including, but not limited to, arbitration or litigation, that the purchaser shall pay to TRAMCO, INC. all costs involved in such dispute and all other out-of-pocket expenses, including in each case reasonable attorneys' fees and the court costs incurred by TRAMCO, INC. in such dispute.

ERRORS:

Typographical and stenographic errors contained in this offer are subject to correction by TRAMCO, INC. without liability.

TRAMCO

Tramco Inc. is a Division of Ag Growth Industries Partnership

Part of Ag Growth International Inc. Group

1020 East 19th Street

Wichita, KS 67214

Phone: (316) 264-4604

Fax: (316) 264-7965

website: www.tramcoinc.com

email: sales@tramcoinc.com

© Ag Growth International 2014

