



THE AMAZING

JETBELT™



The Highest Performance at the Best Value!

With the JetBelt™, dry bulk handling is a breeze!

Tramco has been engineering air supported belt systems since the early 1980's and now with state of the art technology JetBelt™ is the highest performing, best value air conveyor system in the industry.

JetBelt™ offers an entirely new level of operating efficiencies for dry bulk handling requirements such as grain, coal, limestone and aggregates. Instead of relying on conventional roller bearings to support the belt, JetBelt™ rides on a thin "cushion of air" for virtually friction-free operation. Its smooth transport and constant air flow mean materials stay on the conveyor belt and dusting is practically eliminated.

JetBelt™ lets you move the same materials faster, more safely, improves working conditions and provides a dramatic reduction in energy and maintenance costs.

The Tramco JetBelt™ is the conveyor system that delivers the most to you and it does it all with air.



TRAMCO...the world's most complete line of chain and enclosed belt conveyors.

TRAMCO conveyors and elevators, "The Quiet Ones" have become the standard of the industry. They are designed, engineered and built for hard work and long life. All models feature non-metallic flights for lower noise levels, minimal maintenance and downtime.

TRAMCO JETBELT™

Air Supported Belt Conveyor

An efficient system requiring less horsepower than other systems. Used for dry bulk handling requirements in a variety of products.

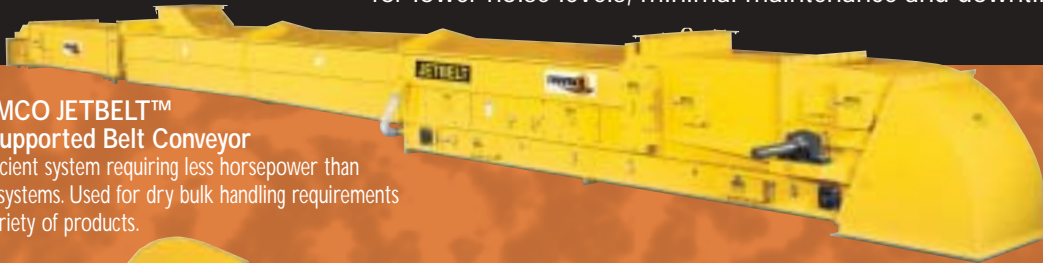

TRAMROLL™

Enclosed belt conveyor with innovative features such as; self-reloading and self-cleaning tail section, and multiple inlets. The heaviest duty design in the industry.



TRAMCO MODEL RB

Designed for self-cleaning and quiet operation with a u-shaped trough for handling soft stock or materials that are easily crumbled or broken.



TRAMCO MODEL G

Built standard with 10-gauge construction to accommodate large capacities of free-flowing materials. Provides years of trouble-free service under extreme applications.



TRAMCO MODEL RS

An economical en-masse conveyor for grain handling. Features a rectangular all-formed mild steel trough. Available in 10-gauge, 3/16" or 1/4" construction. A hard worker for moving soft stock.



TRAMCO BULK-FLO™

The heavy-duty chain conveyor designed specifically for processing applications such as; wet and sticky, varying sizes and densities, and abrasive or corrosive materials.

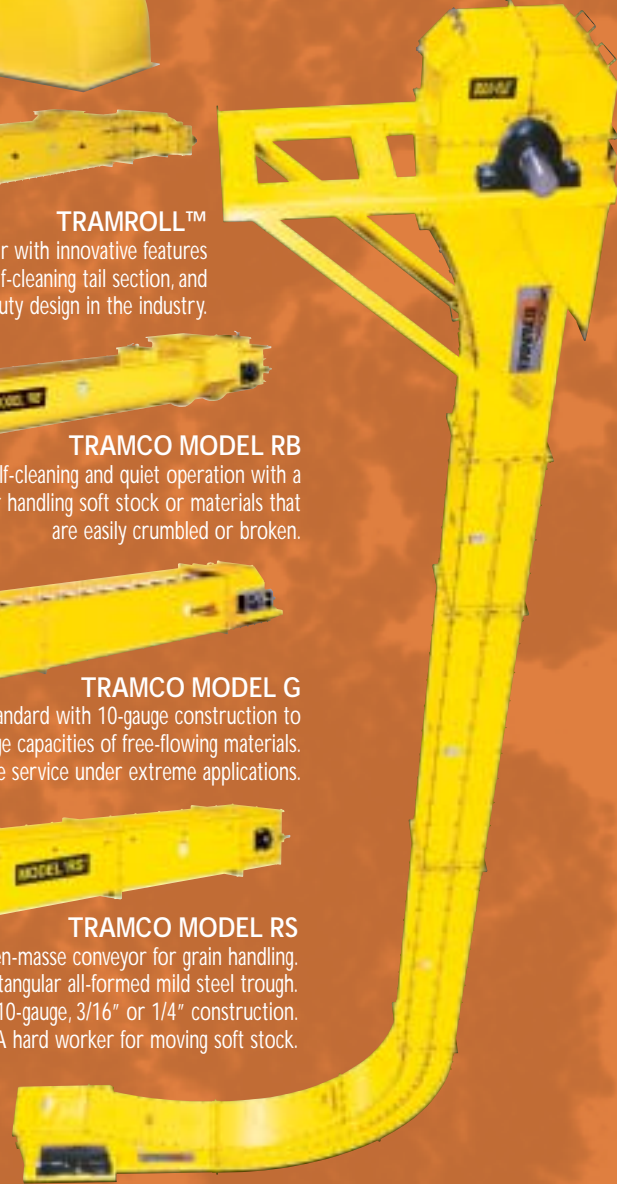

TRAMCO BUCKET ELEVATOR The Work Horse

Centrifugal Discharge design used for the bulk handling of free-flowing fine and loose materials with small to medium size lumps. Built-to-last for the toughest requirements.



TRAMCO, INC. 1020 East 19th Street
Wichita, KS 67214 • Phone: 316-264-4604
Fax: 316-264-7965 • E-mail: sales@tramcoinc.com
Web Site: www.tramcoinc.com

EURO-TRAMCO, B.V.

Space-shuttle 8 G • 3824 ML Amersfoort • The Netherlands
Phone: 011-31-33-4567033 • Fax: 011-31-33-4558149
E-mail: hans@tramco-europe.com

TRAMCO-EUROPE LTD

Unit 1 • Bankside Industrial Estate • Valleta Street
Hull, England HU9 5NP • Phone: 011-44-1482-782666
Fax: 011-44-1482-793920
E-mail: terry@tramcoeurope.karoo.co.uk

JETBELT™

Look, no bearings...just a cushion of air!

The Tramco JetBelt™ is designed for free flowing products in all types of industries. You will find it is a good choice when dust containment is important. It is an efficient system requiring less horsepower and no idlers in the material carrying or empty return pan regardless of the conveying distance. The head section is split making removal of shaft and pulley assemblies easy. The tail section has bolt-on covers and a slot for pulley removal.



Tail section reloading and self-cleaning tail pulley with top hinged access door. V-plow prior to self-cleaning, reloading tail pulley. Inlet. Air curtain belt cleaner—back view. Patent Pending.



Head pulley showing reloading belt cleaner. Internal view of reloading belt cleaner. Patent Pending (Belt not shown).



Here's how the JetBelt™ system works

The load-carrying EZ-FLEX™ Belt is supported by a layer of air between the belt and the pan. The air is supplied from a fan, which pressurizes the air chamber under the pan. The air flows up through holes in the pan. The air is then vented to a dust control system. This unique design allows the JetBelt™ to free span 40 feet and greater.

Tramco uses the EZ-FLEX™ Belt exclusively. With unique qualities which include more lateral elasticity in cold climates and the ability to readily conform to the air film between the belt and the conveyor plenum. This is done without compromising longitudinal strength.

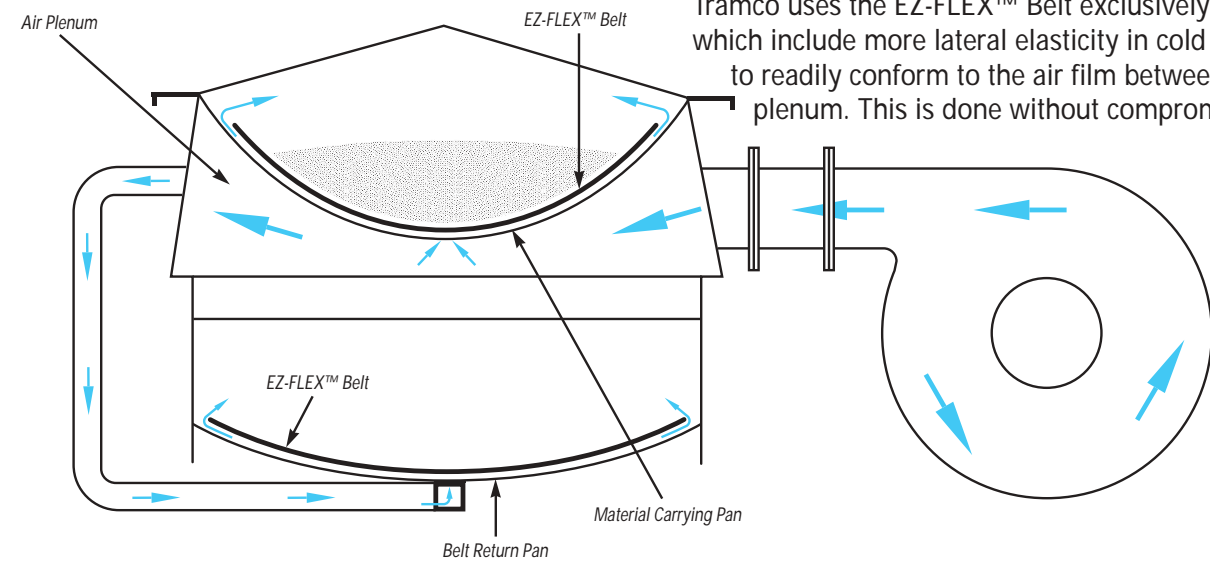

Note: Covers have been removed for illustrative purposes only. Do not operate conveyor unless all covers, guards, etc. are in place.



Air curtain belt cleaner—front view. Patent Pending.



V-plow and reloading belt cleaner. Patent Pending. (Belt not shown).

Transition Idler Access

Packing Gland Seal

